

# SAFETY-VIEW PLUS K. D. 6-TIER STOCK LOCKER ASSEMBLY INSTRUCTIONS

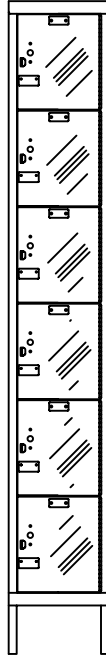

1 WIDE  
6 TIER  
FRONT VIEW

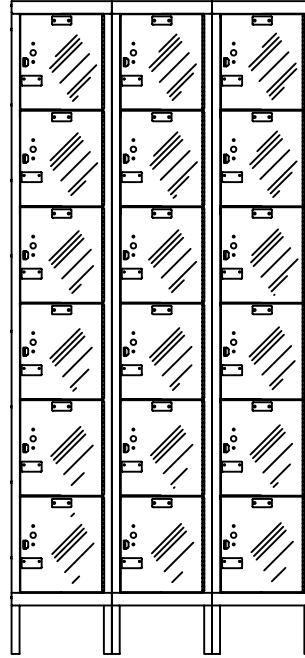

3 WIDE  
6 TIER  
FRONT VIEW

## **General Instructions**

1. Check material received against the packing list. First check the number of packages received and then check the contents of each package.
2. Check material received for damage. If damage has occurred, secure a "damage notation" from the carrier.
3. Identify each part as it is unpacked and put like parts together as close as possible to the working area in which they are to be assembled.
4. Be careful to use the correct hardware as specified in the assembly instructions.
5. Items with suffix (xx) are available options.

## **CAUTION**

IN THE INTEREST OF SAFETY, ALL LOCKERS MUST BE SECURELY ANCHORED TO THE FLOOR AND/OR WALL.  
FOR SAFETY, HANDLE ALL COMPONENTS CAREFULLY AND WEAR WORK-GLOVES WHEN ASSEMBLING LOCKERS.

INSTALL ALL UNITS PLUMB AND TIGHTEN ALL HARDWARE SECURELY.

RETAIN INSTRUCTIONS FOR FUTURE REFERENCE.



401 Jim Moran Blvd., P.O. Box 4157      Phone (954) 429-9662  
Deerfield Beach, FL 33442              Fax (954) 428-3843

**[www.ArtMetalProducts.com](http://www.ArtMetalProducts.com)**

# SAFETY-VIEW PLUS K.D. 6-TIER STOCK LOCKER ASSEMBLY INSTRUCTIONS

## 6-TIER PACKAGE CONTENTS

REF. NO.	DESCRIPTION	PART NO.	1 WIDE QUANTITY 6 TIER		3 WIDE QUANTITY 6 TIER		
①	REAR PANEL	KR1272	1		3		
②	RIGHT/LEFT SIDE PANEL	KPdd72	2		4		
③	TOP/BOTTOM SHELF	KS12dd	2		6		
④	INTERMEDIATE SHELF	KH12dd	5		15		
⑤	DOOR FRAME ASSEMBLY	LKDF1278-6SVP	1		3		
×⑥	DOOR	LKD1272-6SVP	6		18		
⑦	BOX DOOR LATCH PULL	KBLP100	6		18		
xxx⑧	NUMBER PLATE	NPA-E	6		18		
⑨	NUMBER PLATE RIVET	RV101	12		36		
xx⑩	STRIKE PLATE	xxSP100	xx6		xx18		
⑪	REAR LEG	KLG	2		2		
⑫	3/8" SLOTLESS BOLT	MBT200	94		282		
⑬	HEX NUT	N201	82		246		
⑭	HI-DOME CAP NUT	N110	12		36		
×⑮	PIANO HINGE	×PH11	6		18		
×⑯	HINGE (HINGE)	RV102	12		36		

PART NUMBER SUFFIX SHOW WIDTH, DEPTH, HEIGHT AND TIER CUSTOMER TO SPECIFY.

### NOTE:

FOR OPTIONAL INDIVIDUAL SLOPE TOPS,  
SEE SUPPLEMENTAL INSTRUCTION SHEET NO. PKAMP01-A

FOR OPTIONAL 6" HIGH CLOSED METAL BASE,  
SEE SUPPLEMENTAL INSTRUCTION SHEET NO. PKAMP01-B

× SHIPS PRE-HUNG IN FRAME ASSEMBLY.

xx STRIKE PLATES ARE OPTIONAL - INCLUDES TWO REVITS ⑨.

xxx CUSTOMER TO SPECIFY NUMBER SEQUENCE.

### PART NO. LEGEND:

dd = DEPTH

## TWO-YEAR WARRANTY

ART METAL PRODUCTS K.D. LOCKERS ARE COVERED AGAINST ALL DEFECTS IN MATERIALS AND WORKMANSHIP EXCLUDING FINISH, DAMAGE RESULTING FROM DELIBERATE DESTRUCTION AND VANDALISM FOR A PERIOD OF TWO YEARS.



# SAFETY-VIEW PLUS K.D. 6-TIER STOCK LOCKER ASSEMBLY INSTRUCTIONS

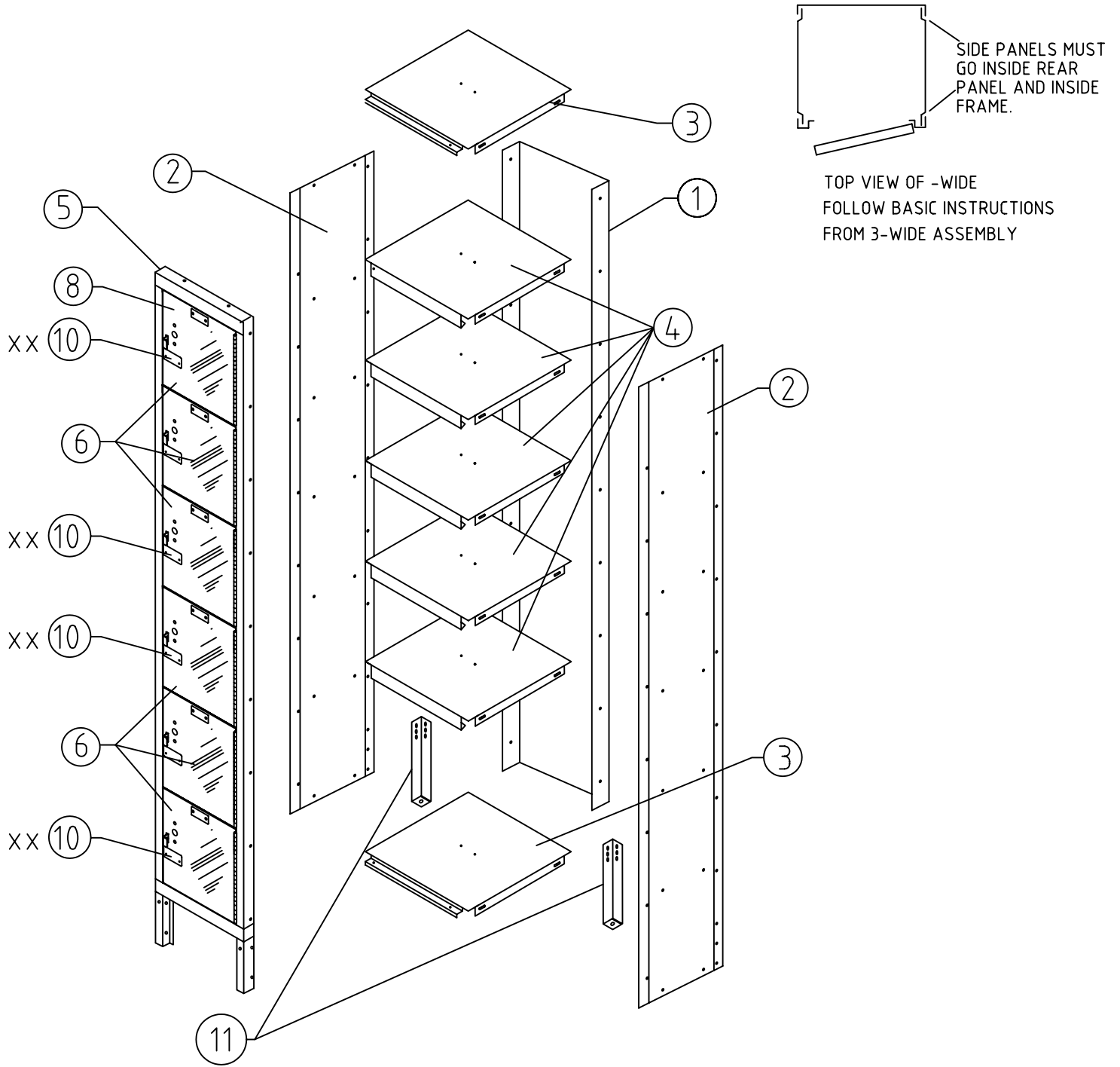

ART METAL PRODUCTS MAKES EVERY EFFORT TO ENSURE THAT ALL UNITS SHIP COMPLETE; HOWEVER, SHOULD YOUR UNIT CONTAIN MISSING OR DAMAGED PARTS, REPLACEMENTS MAY BE OBTAINED FROM ART METAL PRODUCTS. TO OBTAIN PARTS, FOLLOW THESE INSTRUCTIONS.

## PLEASE PROVIDE THE FOLLOW INFORMATION:

MODEL NUMBER

PURCHASE DATE

DESCRIPTION OF PART(S) NEEDED & PART NUMBER(S) AS SHOWN IN PARTS LIST

COMPANY NAME & CONTACT PERSON

COLOR

WHERE THE PRODUCT WAS PURCHASED FROM

IF REQUESTING PARTS BY TELEPHONE, ASK FOR CUSTOMER SERVICE & PROVIDE THE ABOVE INFORMATION.



# SAFETY-VIEW PLUS K.D. 6TIER STOCK LOCKER ASSEMBLY INSTRUCTIONS

(A GROUPING OF (3) THREE 6-TIER LOCKERS ILLUSTRATED)

## STEP 1

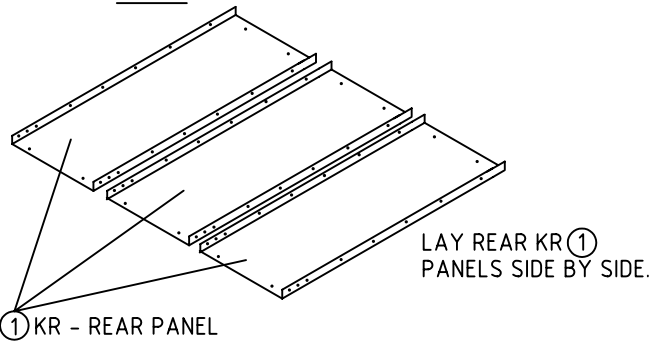

## STEP 2

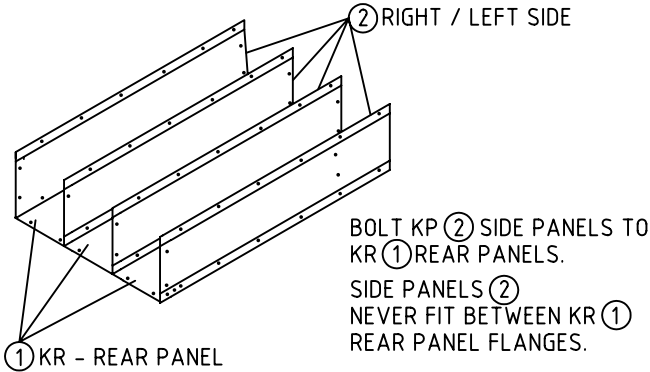

TOOLS REQUIRED: 3/8" NUT DRIVER  
(3/8" SOCKET MAY BE SUBSTITUTED)

## STEP 3

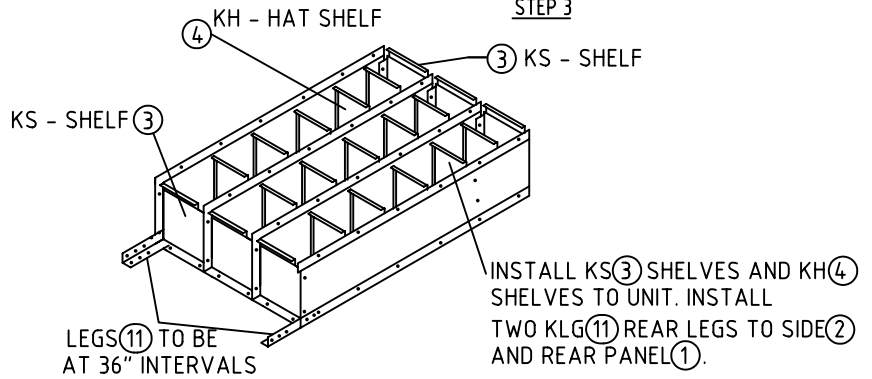

## STEP 4

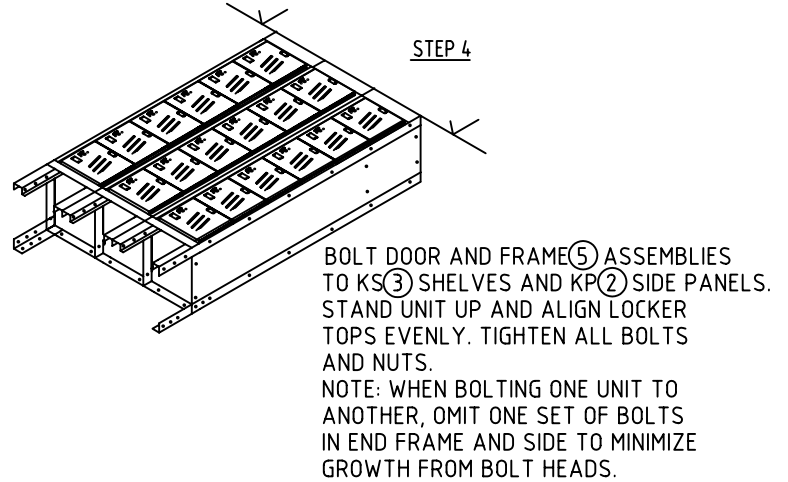

### ASSEMBLY OF SINGLE ROW LOCKERS NEVER PUT SIDE PANELS BETWEEN FRAMES.

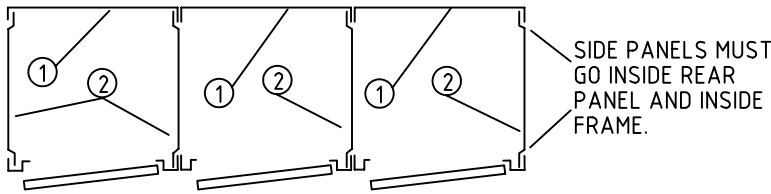

3 WIDE UNIT PLAN VIEW

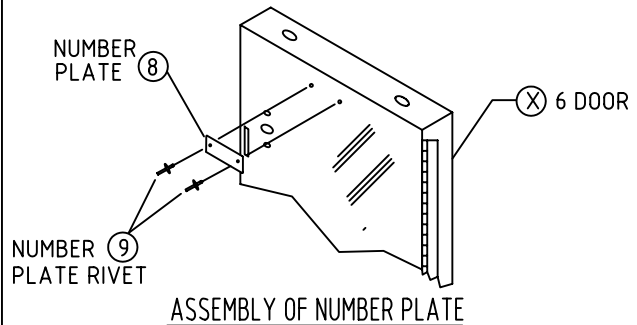

### HARDWARE USED FOR MAIN LOCKER ASSEMBLY



10 - 24 x 3/8"

MBT200 SLOTLESS BOLT (12)



N201 HEX NUT (13)

TIGHTEN NUT WITH A NUT DRIVER OR WRENCH  
(SCREW IS TAMPER RESISTANT).

