

LOCK ALIGNMENT PLATE

Installation Instructions for

Magnum and Bulldog Single-Point Lockers Using Built-In Combination Locks

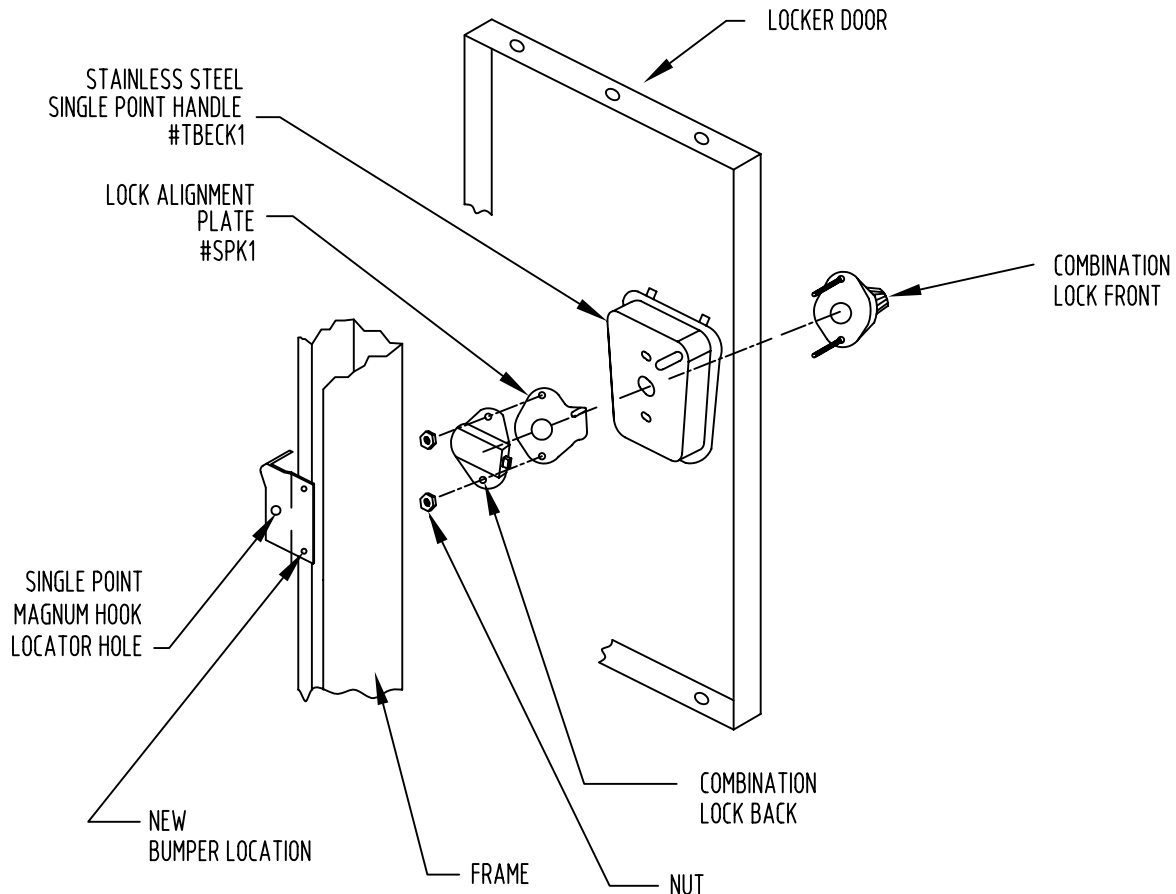

1. Remove bumper from Magnum hook and install in lower hole.
2. Insert combination lock front thru recessed handle.
3. Place the Magnum LOCK ALIGNMENT PLATE, followed by the combination lock back on the back of the recessed handle as shown.
4. Finger tighten the nuts only. This will allow the LOCK ALIGNMENT PLATE and lock to move into proper alignment with the Magnum hook..
5. Use the key to hold the lock bolt in the open position and push the door closed gently to allow the LOCK ALIGNMENT PLATE tab to locate the hole in the Magnum hook.
With the tab inserted in the hook hole, the lock is now located in the optimum position.
6. When good alignment is made, tighten the nuts with a 3/8" nut driver taking care not to move the lock.

TWO-YEAR WARRANTY

ART METAL PRODUCTS K.D. LOCKERS ARE COVERED AGAINST ALL DEFECTS IN MATERIALS AND WORKMANSHIP EXCLUDING FINISH, DAMAGE RESULTING FROM DELIBERATE DESTRUCTION AND VANDALISM FOR A PERIOD OF TWO YEARS.



401 Jim Moran Blvd., P.O. Box 4157 Phone (954) 429-9662
Deerfield Beach, FL 33442 Fax (954) 428-3843

www.ArtMetalProducts.com